



SI B 24 05 95  
Automatic Transmission

October 1999  
Product Engineering

**SUBJECT**  
**EGS/AGS Control Module EPROM Replacement**

**MODEL**  
Vehicles with automatic transmission

**SITUATION**  
In case of a customer complaint pertaining to shift quality, the EPROM in the EGS/AGS control module should be replaced by following the steps indicated in the attached procedure.

**PROCEDURE**  
Install an updated EPROM into the transmission control module using the instructions provided. For easier reference this procedure is broken up into the following:

- A. Preparatory EPROM Replacement Instructions
- B. EPROM REPLACEMENT for ZF Transmissions and THMR1 A4S-310R with 88 pin connector
- C. EPROM REPLACEMENT for THM-R1 A4S-310R (55 pin connector)

**WARRANT INFORMATION**  
For Information only.

**PROCEDURE A**  
**Preparatory EPROM Replacement Instruction**

The installation of the updated EPROM into the engine control module is a simple procedure.

However, before beginning the EPROM exchange the following conditions must be provided and the designated tools must be used.

**ENVIRONMENT**

The work area where the EPROM is exchanged must be free of excessive dust and aggressive chemicals or vapors. A small uncarpeted office within the dealership is recommended. Since low atmospheric humidity promotes static electricity, an evaporating bowl of water can be used to raise the humidity level of the work area.

**EQUIPMENT**

Screwdriver (blade type) is used to open and close the control module. The EPROM is exchanged using an IC extractor/insert set. Tool set can be obtained locally (Radio Shack, Archer #276-1581).

**STATIC ELECTRICITY**

The engine control module can be damaged and rendered unusable by static electrical discharge. For this

078257

reason the 3M static protection kit or equivalent) must be used and properly grounded during the entire EPROM exchange procedure.

## EPROM STORAGE

Replacement EPROMs must be stored in the original shipment containers. The label in the center of the EPROM must never be removed.

## PROCEDURE B

### **EPROM REPLACEMENT for all ZF Transmissions AND THMR1 A4S 310R with 88 pin connector.**

**CAUTION** - Whenever connecting or disconnecting any control module the IGNITION MUST BE SWITCHED OFF.

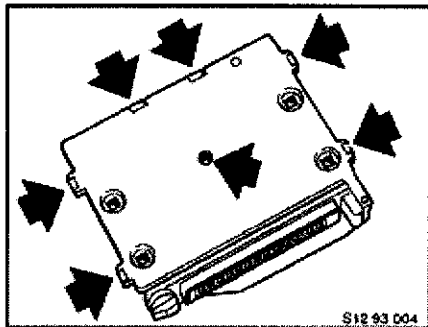

1. Lay the control module on a static mat and carefully bend up the 6 taps.

Remove the plastic retaining pin using a small screwdriver and needle nose pliers.

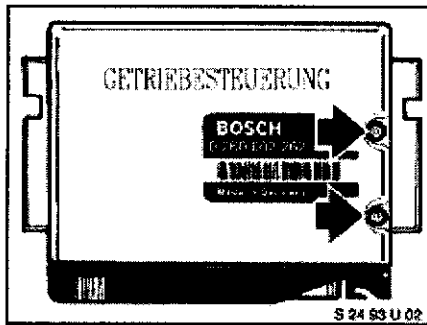

2. Remove the 2 torx screws (TORX T20) from the cover of control module.

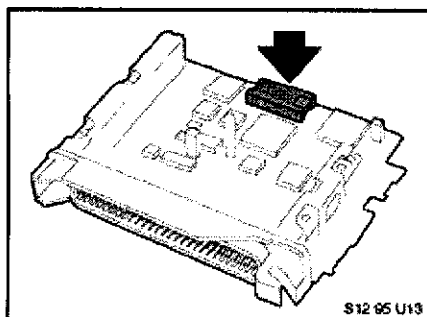

Remove the protective cap from the EPROM(as described below).

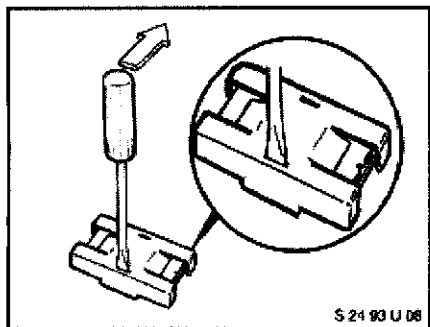

3. Remove the protective cap from the EPROM by inserting a small screwdriver into one of the slots on the side of the cap.

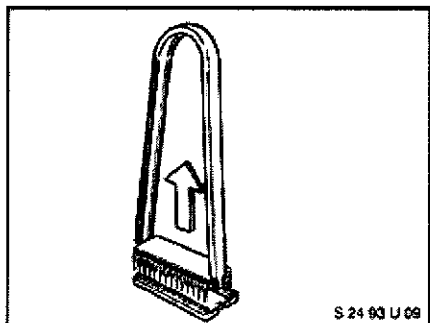

4. Remove EPROM by using an IC extractor tool and carefully pulling it out of the socket. Caution: Do not touch contact pins of the EPROM.

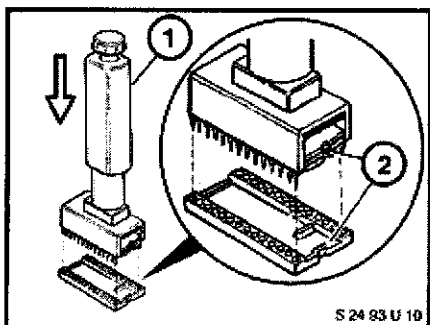

5. Reinstall new EPROM, making certain that:
  - a. All pins are straight.
  - b. The notch in the EPROM and the notch in the socket are aligned.
  - c. That all pins have been inserted into the socket correctly and completely.

6. Reassemble the control unit by:
  - a. Reinstalling EPROM cap.
  - b. Carefully reinstall the cover, making certain that none of the taps on the cover come in contact with any of the pins on the PC board.
  - c. Secure the cover to module by reinstalling 2 Torx screws.
  - d. Carefully bend the taps down.

**PROCEDURE C:**

**For replacing the EGS EPROM with a THM-R1 A4S310R transmission with 55 pin connector.**

**CAUTION - Whenever connecting or disconnecting any control module the IGNITION MUST BE**

SWITCHED OFF.

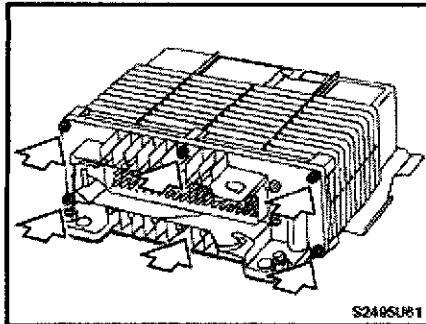

1. Remove the six torx screws located around the connector housing.

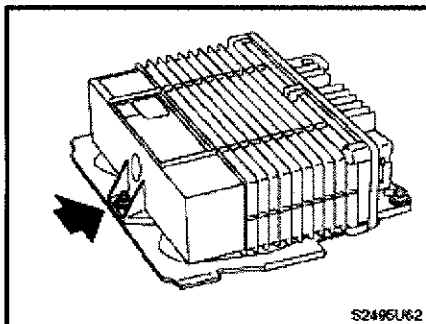

2. Remove the 10mm nut and washer used to secure the control module to the mounting bracket.

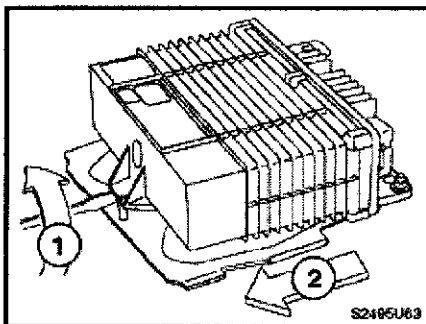

3. Separate the control module cover from mounting bracket, (1) by holding the control module cover and pulling back on the mounting bracket. (2) Once cover is separated from bracket, grab the front of the control module while still holding the cover and pull the cover back exposing the PC board inside.

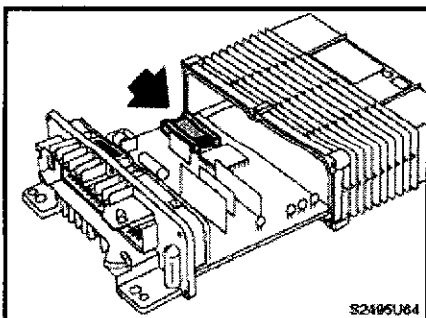

4. With the PC board exposed remove the security cap holding the EPROM by inserting a small straight blade screwdriver into the slot on the cap and gently pry the bottom of the cap away from the EPROM base.

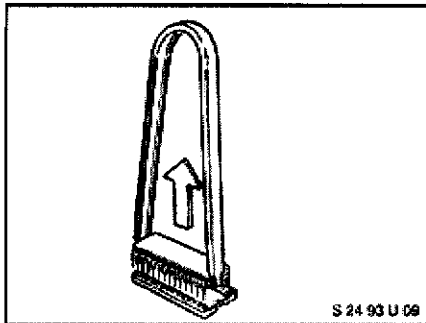
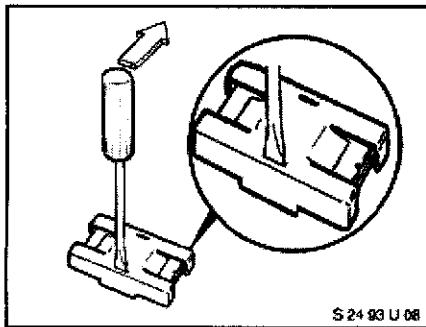

5. Remove the EPROM from its base by using an IC extractor tool. Caution: Do not touch the contact pins of the EPROM.

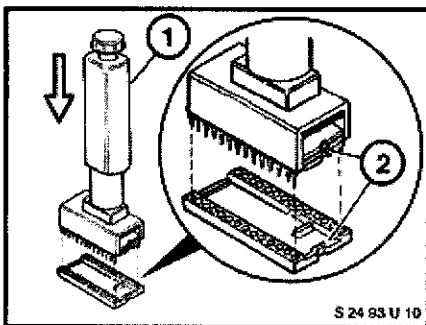

6. Install the new updated EPROM using an IC inserter tool.

- All pins are straight.
- The notch in the EPROM and the notch in the socket are aligned.
- That all pins have been inserted into the socket correctly and completely.

7. Place the security cap over the EPROM and reassemble the control module.